

Design Aids for the Central Florida Water Initiative (CFWI) Supplemental Applicant's Handbook

These Design Aids are not incorporated by reference in Chapter 62-41, F.A.C., and therefore do not constitute rules of the Agencies. They are intended solely to provide applicants with useful tools, example calculations, and design suggestions that may assist with the requirements within Chapter 62-41, F.A.C.

FOR USE STATEWIDE BY AND FOR THE:
FLORIDA DEPARTMENT OF ENVIRONMENTAL PROTECTION
ST. JOHNS RIVER WATER MANAGEMENT DISTRICT
SOUTHWEST FLORIDA WATER MANAGEMENT DISTRICT
SOUTH FLORIDA WATER MANAGEMENT DISTRICT



April, 2024

Table of Contents

Design Aid 1: Example Water Balance Diagram_____	3
Design Aid 2: Annual Conservation Goal Implementation Plan Template_____	4
Design Aid 3: Public Supply Annual Report Template_____	5
Part A. Per Capita Water Use Rate_____	5
Definitions for Part A_____	6
Part B. Residential and Non-residential Water Use_____	8
Definitions for Part B_____	9
Part C. Residential Per Capita Water Use Goal_____	10
Design Aid 4: Application of Section 2.8 of the CFWI Supplemental Applicant’s Handbook to Permits with Multiple Sources_____	11
Design Aid 5: Guidelines for Preparation of Reuse Feasibility Studies for Consumptive Use Permit Applications_____	14
Design Aid 6: Calculation of the Maximum Safe Yield of Well for the Prevention of Upconing_____	15

DESIGN AID 1: Water Balance Diagram Example

Figure 2-1 Example Water Balance Diagram

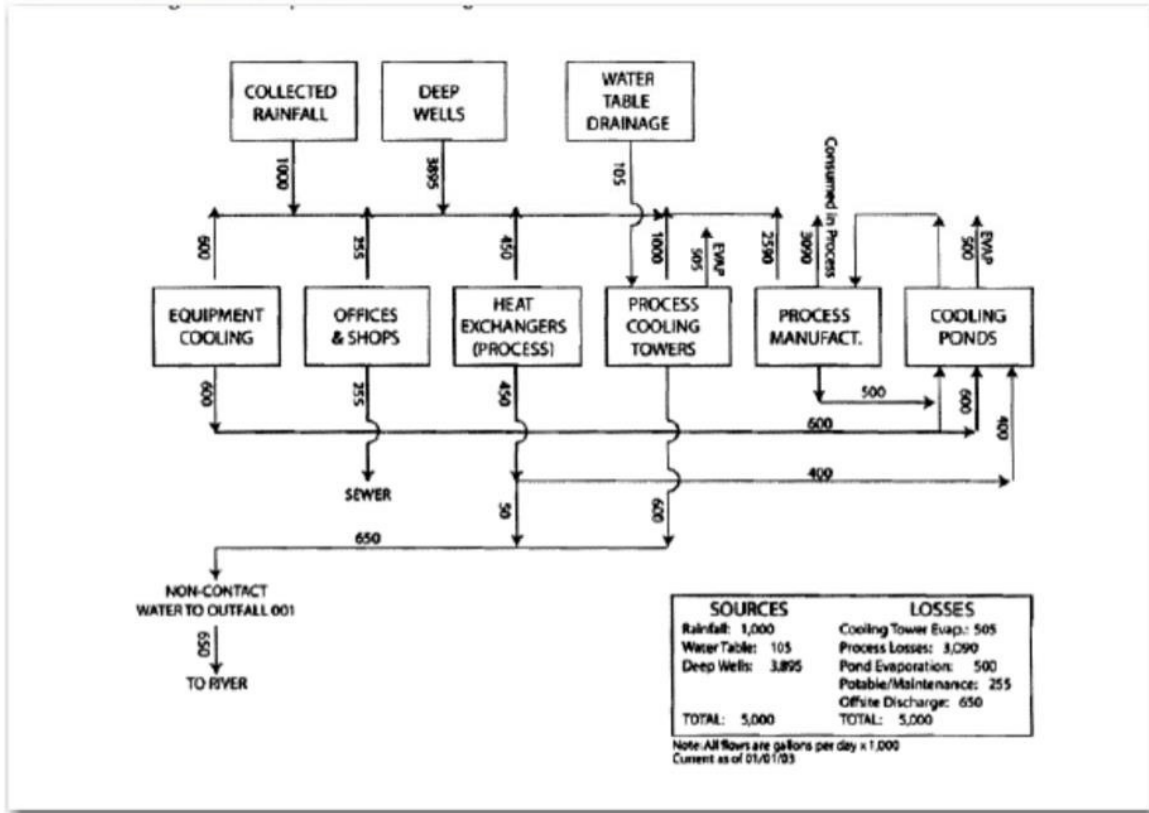

DESIGN AID 2: Annual Conservation Goal Implementation Plan

The following page reflects a sample of the Annual Conservation Goal Implementation Plan that may be used by water users in their complete discretion.

GENERAL INFORMATION	
Permittee Name	
CUP Number	
Person(s)/Position(s) Responsible for ACGIP	
Last Updated Date	
Signature of Responsible Person	

ACGIP Term, if applicable	<i>Enter the years the ACGIP is applicable for. It must be at least 5 years (current year plus 4 additional years) or for the term of the permit, whichever is less.</i>
Annual Conservation Goal Type	<input type="checkbox"/> Conservation BMPs & Conservation Programs <input type="checkbox"/> Other Metrics

CONSERVATION BMPS AND CONSERVATION PROGRAMS				
Time Period	BMP or Conservation Program	Strategy Associated with the Goal	Achieved/ Not Achieved	Estimated Water Savings <i>(optional)</i>
<i>Enter the year or years you intend to implement the listed BMP/Program</i>	<i>Briefly state the BMP or conservation program (e.g., toilet rebates).</i>	<i>Briefly describe the strategy associated with the BMP or conservation program (e.g., 600 toilet rebates are made available and will be promoted via social media targeting residential houses built before 1994.)</i>	<i>State whether the goal was achieved or not achieved</i>	<i>Option to include the estimated water savings associated with implementing the BMP or conservation program.</i>

**Add additional rows for each BMP.*

OTHER METRIC			
Time Period	Metric	Achieved/ Not Achieved	Estimated Water Savings <i>(optional)</i>
<i>Enter the year or years you intend to implement the listed BMP/Program</i>	<i>Briefly state the metric (e.g., achieving a set per capita reduction; achieving and maintaining an efficiency for a system) and how it will be measured annually.</i>	<i>State whether the goal was achieved or not achieved</i>	<i>Option to include the estimated water savings associated with achieving the metric.</i>

**Add additional rows for each metric.*

RESIDENTIAL PER CAPITA WATER USE (for Public Supply only)
<input type="checkbox"/> Residential per capita: _____ gcpd <i>Use the formula: Total Residential Water Use (or Water Use by Dwelling Units) divided by Service Area Residential Population</i>

DESIGN AID 3:
20__ Public Supply Annual Report
For Individual Permits Over 100,000 GPD Annual Average Quantities

PART A. Per Capita Water Use Rate

Please submit water use information for January 1 – December 31, 20___. The information included in this Design Aid is required to be submitted as a condition on your Water Use Permit (WUP). Requirements are given in detail in section 2.7.3.1 of the Central Florida Water Initiative Supplemental Applicant’s Handbook.

WUP No(s):		Reporting period (mo/yr-mo/yr):	
Issue Date (of the most recent revision of the WUP):		Contact Phone #:	
Permittee Name:		Contact Name:	
Address:		County:	
	Equation Component	WATER USE CATEGORY	Annual Average Quantity
1	WD	Total Withdrawals ground water, surface water, and stormwater. Attach meter readings and pumpage from 1/1/ through 12/31/ .	gpd
2	IM	Imported Water Supply itemized list of quantities per supplier. If applicable, include the WUP number (CUP No.) of each supplier listed.	gpd
3	EX	Exported Water Supply itemized list of quantities per receiver. If applicable, include the WUP number (CUP No.) of each receiver listed.	gpd
4	Gross Water Use: $WD + IM - EX$		gpd
5	<input type="checkbox"/> RP <input type="checkbox"/> FP	Residential Population Served, or Functional Population (Check box and supply supporting calculations, see instructions)	# people
6	Gross Per Capita = $(WD + IM - EX)/RP$ or FP		gpcd
7	TL	Water Treatment Loss (Provide documentation of each type claimed.)	gpd
8	SU	Significant Uses Provide documentation of deductions as required in the Supplemental Applicant’s Handbook and include a separate report summarizing significant uses.	gpd
9	GC	Golf Course Deduction (See definitions for requirements and limitations.)	gpd
10	EM	Environmental Mitigation if required by the District per your water use permit (attach documentation of quantities used).	gpd
11	Adjusted Gross Per Capita = $(WD + IM - EX - TL - SU - GC - EM)/RP$ or FP		gpcd
12	ST	Stormwater Deduction (See definitions for requirements and limitations.)	gpd
13	RW	Reclaimed Water Deduction (See definitions for requirements and limitations.)	gpd
14	Alternative Per Capita = $(WD + IM - EX - TL - SU - GC - EM - ST - RW)/RP$ or FP		gpcd

15	Per Capita Noncompliance Report: A report explaining why a utility had a Compliance Per Capita rate greater than 100 gpd. The report shall include an explanation detailing why the per capita water use rate was not achieved, measures taken to comply with the per capita water use rate of 100 gpd, and a plan that identifies conservation or water supply project(s) that will be developed and implemented to achieve the per capita water use rate of 100 gpd	<input type="checkbox"/> Attached <input type="checkbox"/> N/A
16	Service Area Map: Submit a map or file showing the current utility service area. Any changes to the utility service area relative to the existing boundaries in the District's Geographic Information System (GIS) layer must be identified and documented.	<input type="checkbox"/> Attached <input type="checkbox"/> Unchanged

Definitions for Part A:

Instructions regarding Per Capita Daily Water Use Rate calculations: Only complete the per capita calculations that show a per capita rate of 115 gpd or less if using Residential Population, or 100 gpd or less if using Functional Population. If the goal is met using the Gross Per Capita Water Use Rate, the Adjusted Per Capita does not have to be calculated. If the goal is met using the Adjusted Per Capita rate, then the Alternative Per Capita does not have to be calculated.

Total Withdrawals (Raw Water Pumpage): Annual average gallons per day ground water, surface water and stormwater withdrawals as metered at the wellhead(s), wellfield's departure point, or surface water intake facility.

Imported Water: Annual average water imported or purchased from other supplier(s). Irrigation water, excluding reclaimed water, provided to the applicant's service area by a separate utility shall be counted as imported water.

Exported Water: Annual average gallons per day of water transferred in bulk quantities from your utility to other potable water suppliers. Determine quantities at the departure point from your service area.

Water Treatment Loss: Annual average gallons per day which are lost in routine treatment for potability. Examples of treatment loss types are desalination reject, membrane cleaning and sand filtration backwash. Treatment losses are calculated as raw water into the plant minus treated water out of the plant. Treated water volume delivered to the distribution system includes water from withdrawals plus imports, minus exports, minus treatment losses. Treatment loss and line flushing quantities shall be separately calculated and documented.

Residential Population: The population within a utility's service area, based upon total residential dwelling units served, which include Single Family Residential, Multi-Family Residential (apartments, townhomes, condos, duplexes) and Mobile Homes, multiplied by a utility-specific estimate of persons per household. Utility-specific persons per household should be based on a reasonable method of calculation, such as census-based averages, BEBR persons per household estimates, and utility documented surveys.

Functional Population: The served permanent population as adjusted by the seasonal resident, tourist, group quarters, and net commuter population within a utility's service area.

Significant Uses: Includes Single Significant Uses, Combined Regional Government and Higher Education Facilities, Individual Regional Health Facilities, and Individual Industrial/Commercial Facilities Where Water is the Primary Ingredient of the Final Product, as defined in Section 2.7.3.A. of the CFWI Supplemental Applicant's Handbook.

Environmental Mitigation Use: Separately-metered annual average quantities used by a utility to mitigate withdrawal-related stress to a specified environmental feature as required by the utility's Water Use Permit.

Golf Course Deduction: Separately metered golf course irrigation quantities from ground water, surface water, reclaimed water or stormwater provided to golf courses inside the service area. The quantities provided may be deducted only if they are included in the permitted quantities for the service area and reported as withdrawals (WD) in the Annual Report. The "GC" withdrawal quantities deducted shall not exceed those actually provided, or those that would be permitted for use by the District, whichever is less.

Reclaimed Water Deduction: Standard deduction of 50%, or if the Applicant chooses, up to the limit of the actual amount of reclaimed water that has received at least secondary treatment and is provided to directly replace an existing or potential use of higher quality water. To be deducted, it must first be provided to any metered use located outside the utility potable service area boundary and then to any single-site separately-metered use within the utility potable service area boundary that uses 25,000 gallons per day or more on an annual average basis during the per capita reporting period, except that no deduction shall be taken for quantities used for residential irrigation (single family, multi-family or mobile home) or for common area irrigation, including entranceways, parking lots, irrigated areas within roadway right-of ways (e.g., road and sidewalk medians), open spaces, community areas, and public parks. Any deduction over the standard 50% reclaimed water per capita credit must be substantiated with verifiable and corresponding reductions in the supplied WUP pumpage (all deductions subject to District approval).

Stormwater Deduction: Separately metered and reported stormwater quantities captured by the permittee that are included in the utility's permitted quantities for uses inside the service area other than for golf course irrigation. The stormwater withdrawal quantities deducted shall not exceed the quantities actually provided, or those that would be permitted for the use by the District, whichever is less. Stormwater quantities deducted as golf course (GC) use above may not be included in this deduction for stormwater. The surface withdrawal points from the stormwater catchments shall be permitted on the provider's water use permit and must be reported as withdrawals in the Annual Report to be deducted. The stormwater deduction shall not be taken where the quality of the ground water source to be permitted or replaced is of lower water quality but is suitable for the intended use, unless the use of the stormwater in such cases reduces adverse impact to the water resources.

Service Area Map: Please review the public supply service area maps currently in the District's Geographic Information System (GIS) to determine if updating is necessary. Make any changes relative to the existing boundaries in the District's layer and complete the service area information forms attached. If updating is not necessary, please indicate so.

PART B. Residential and Non-Residential Water Use

Please submit water use information for January 1 – December 31, 20__.

SERVICE CATEGORIES: Quantities to be reported are **annual average gallons per day** (total number of gallons supplied per reporting period, divided by 365 days per year) and are to include both indoor and outdoor use, whether separately metered or not. On a separate sheet, permittees are to document the methodology used to determine the number of dwelling units by type and their quantities used. Estimates of water use based on meter size will not be accepted. If mobile homes are included in the Permittees multi-family unit category, the information for them does not have to be separated.

Residential Water Service Category	Number of Dwelling Units	Number of Metered Connections	Annual Average (gpd)	% of Total	Documentation on an Attached Sheet
1. Single Family Dwelling Units					<input type="checkbox"/> Yes <input type="checkbox"/> No
2. Multiple Family Dwelling Units					<input type="checkbox"/> Yes <input type="checkbox"/> No
3. Mobile Home Dwelling Units					<input type="checkbox"/> Yes <input type="checkbox"/> No
4. Residential Irrigation Accounts	N/A				<input type="checkbox"/> Yes <input type="checkbox"/> No
5. Subtotal of Residential Service					<input type="checkbox"/> Yes <input type="checkbox"/> No
Non-Residential Water Service Category		Number of Metered Connections	Annual Average Gallons Per Day	% of Total	
6. Industrial/Commercial Uses					
7. Agricultural Uses					
8. Recreational/Aesthetic Uses					
9. Golf Course Irrigation					
10. Fire and Other Accounted Uses					
11. SUBTOTAL (Add items 5 through 10)					
12. Water Loss					
TOTAL (Add items 11 and 12)(= line 4 on Part A)				100	

Definitions for Part B:

Note: Utilities serving municipalities shall provide dwelling unit, use, and connection data for all accounts regardless of whether they are categorized as “inside” or “outside” city for rate purposes. Dwelling units that are intended as public accommodations shall not be included in dwelling unit counts if they are also used in the calculation of tourist population.

Single Family Dwelling Units: These are single, detached dwelling units intended for private residential use, whether individually or master-metered. If the utility categorizes mobile homes or duplexes as single family dwelling units that is acceptable if noted and they are not counted in other dwelling unit categories. Provide the number of single family units served (not accounts/connections) and the number of metered connections serving these units.

Multiple Family Dwelling Units: These are attached dwelling units in structures containing two or more residences, whether individually or master-metered. Provide the number of dwelling units served (not accounts/connections) and the number of metered connections serving these units. If the utility categorizes mobile homes as multi-family units, that is acceptable if noted and they are not counted in other dwelling unit categories. Data associated with multifamily dwelling units such as water use and metered connections must be reported as residential, even though classified as commercial by the utility.

Mobile Home Dwelling Units: Dwelling units capable of being moved from one location to another. This excludes manufactured or prefabricated housing that are not intended to be moved. If mobile homes are counted as single family dwelling units by your utility, they can be included under the single family dwelling unit category, but not both mobile home and single family. Mobile homes can be counted as multiple family dwelling units if so categorized by your utility, but not both mobile home and multiple family. Please note how mobile homes are being categorized if other than in the mobile home category.

Indoor/Outdoor Residential Use: Most residential water use is not metered separately for a customer’s indoor and outdoor use. Thus, the metered water quantities on the single or master meter will include both use types. However, if there is a separate meter for outdoor use (irrigation water for associated lawn and ornamentals) for any type of dwelling unit, that “outdoor” quantity is to be documented under the residential irrigation accounts water use.

Industrial/Commercial Use: Include retail/wholesale, manufacturing, processing, government buildings, libraries, airports, universities, and other such accounts in this category. Permittees are not to include multi-family connections that are classified internally as commercial accounts in this category; rather, these are to be counted in the Multiple Family Dwelling Units category, and the number of dwelling units provided. Include lawn & landscape irrigation quantities associated with this category.

Agricultural Use: Provision of water for the irrigation of hay fields, row crops, citrus, etc., or other agricultural use. This does not include quantities associated with irrigation of a lawn that is connected with a residential account or irrigation of grounds associated with multiple family or mobile home dwelling units.

Recreational/Aesthetic Use: Provision of separately metered water for the irrigation of commercial entities, parks, theme parks (water parks, recreational attractions), aquariums or other

use for recreational purposes or for visual enhancement (excluding the irrigation for golf courses and associated clubhouse grounds). Note: irrigation accounts associated with residential development use should be counted in the appropriate residential category.

Golf Course Irrigation: Provision of separately metered water for the irrigation of golf courses and associated clubhouse grounds.

Water Loss: The total water system output minus all accounted uses. Water losses include: leakage associated with transmission and distribution mains, overflow and leakage from storage tanks, leakage near service connections, illegal connections, flushing of distribution lines in excess of 1% of the total distribution volume delivered to the distribution system, unmeasured flows associated with fire suppression, as well as un-metered system testing, under-registration of meters, and other discrepancies between the metered amount of finished water output from the treatment plant less the metered amounts specified herein.

PART C. Residential Per Capita Water Use Goal

Please submit water use information for January 1 – December 31, 20 . The information included in this Design Aid is required to be submitted as a condition on your Water Use Permit. Requirements are given in detail in Section 2.7.2 of the Central Florida Water Initiative Supplemental Applicant’s Handbook.

	WATER USE CATEGORY	Annual Average Quantity
1	Total Residential Water Use (Section B, Line 5)	gpd
2	Residential Population Served (Section A, Line 5)	# people
3	Residential Per Capita Water Use Goal: Total Residential Water Use/RP	gpcd

DESIGN AID 4:

Application of Section 2.8 of the CFWI Supplemental Applicant’s Handbook to Permits with Multiple Sources

The following are examples of how the requirements in Section 2.8 of the CFWI Applicant’s Handbook will apply to permittees with multiple water sources, with at least one source that includes the Upper Floridan aquifer. These examples are provided for informational purposes only.

Example #1

A permittee has a total permitted allocation of 20 million gallons per day (mgd), with 10 mgd from the Upper Floridan Aquifer (UFA) and 10 mgd from surface water. The permittee’s 2025 Demonstrated Demand is 15 mgd. Section 2.8 limits the UFA allocation to the 2025 Demonstrated Demand. Since the 2025 Demonstrated Demand is *more* than the current allocation from the UFA, there is no reduction needed to the UFA allocation.

New UFA Allocation: 10 mgd (no change)

New Total Allocation: 20 mgd (no change)

Current Allocation	2025 Demonstrated Demand	New UFA Allocation	New Total Allocation
Total: 20 mgd	Total: 15 mgd	No Change	Total: 20 mgd (no change)
<ul style="list-style-type: none"> • 10 mgd UFA 			<ul style="list-style-type: none"> • 10 mgd UFA
<ul style="list-style-type: none"> • 10 mgd Surface Water 			<ul style="list-style-type: none"> • 10 mgd Surface Water

Example #2

A permittee has a total permitted allocation of 20 mgd, with 15 mgd from UFA and 5 mgd from the Lower Floridan aquifer (LFA). The permittee’s 2025 Demonstrated Demand is 12 mgd. Since the 2025 Demonstrated Demand is *less* than the current allocation from the UFA, the UFA allocation is reduced by the difference (3 mgd).

New UFA Allocation: 12 mgd (reduction of 3 mgd)

New Total Allocation: 17 mgd (reduction of 3 mgd, no change to AWS quantities)

Current Allocation	2025 Demonstrated Demand	New UFA Allocation	New Total Allocation
Total: 20 mgd	Total: 12 mgd	12 mgd (reduction of 3 mgd)	Total: 17 mgd (reduction of 3 mgd)
<ul style="list-style-type: none"> • 15 mgd UFA 			<ul style="list-style-type: none"> • 12 mgd UFA
<ul style="list-style-type: none"> • 5 mgd LFA 			<ul style="list-style-type: none"> • 5 mgd LFA

Note that in this example, the 3 mgd reduction to the UFA allocation may be lessened if the permittee has implemented applicable water supply or water resource development projects since December 2015. See Section 2.8.4 of the Supplemental Applicant’s Handbook for more information.

Example #3

A permittee has a total permitted allocation of 20 mgd, with 15 mgd from UFA and 5 mgd from the LFA. The permittee’s 2025 Demonstrated Demand is 7 mgd. Since the 2025 Demonstrated Demand is *less* than the current allocation from the UFA, the UFA allocation is reduced by the difference (8 mgd).

New UFA Allocation: 7 mgd (reduction of 8 mgd)

New Total Allocation: 12 mgd (reduction of 8 mgd, no change to AWS quantities)

Current Allocation	2025 Demonstrated Demand	New UFA Allocation	New Total Allocation
Total: 20 mgd	Total: 7 mgd	7 mgd (reduction of 8 mgd)	Total: 12 mgd (reduction of 8 mgd)
• 15 mgd UFA			• 7 mgd UFA
• 5 mgd LFA			• 5 mgd LFA

Note that in this example, the 8 mgd reduction to the UFA allocation may be lessened if the permittee has implemented applicable water supply or water resource development projects since December 2015. See Section 2.8.4 of the Supplemental Applicant’s Handbook for more information.

Example #4

A permittee has a total permitted allocation of 20 mgd, with 10 mgd from UFA and 10 mgd from the LFA. The permittee’s 2025 Demonstrated Demand is 8 mgd. Since the 2025 Demonstrated Demand is *less* than the current allocation from the UFA, the UFA allocation is reduced by the difference (2 mgd).

New UFA Allocation: 8 mgd (reduction of 2 mgd)

New Total Allocation: 18 mgd (reduction of 2 mgd, no change to AWS quantities)

Current Allocation	2025 Demonstrated Demand	New UFA Allocation	New Total Allocation
Total: 20 mgd	Total: 8 mgd	8 mgd (reduction of 2 mgd)	Total: 18 mgd (reduction of 2 mgd)
• 10 mgd UFA			• 8 mgd UFA
• 10 mgd LFA			• 10 mgd LFA

Note that in this example, the 2 mgd reduction to the UFA allocation may be lessened if the permittee has implemented applicable water supply or water resource development projects since December 2015. See Section 2.8.4 of the Supplemental Applicant’s Handbook for more information.

Example #5 (Incorrect Calculation)

Using the same scenario as Example #1 above, this example shows how the provisions of Section 2.8 would be applied incorrectly.

A permittee has a total permitted allocation of 20 mgd, with 10 mgd from UFA and 10 mgd from surface water. The permittee’s 2025 Demonstrated Demand is 15 mgd. Here the 2025 Demonstrated Demand is *less* than the total allocation, so a reduction of 5 mgd was made to the UFA allocation. This brings the New Total Allocation to 15 mgd, with 5 mgd from the UFA and 10 mgd from surface water.

However, this is incorrect because the rule does not require changes to total allocation; rather it restricts any UFA allocations to the 2025 Demonstrated Demand. The 2025 Demonstrated Demand means the quantity of water needed to meet demands in 2025. Therefore, as the 2025 Demonstrated Demands is *more* than the current allocation for the UFA, there should be no change to the UFA allocation, as correctly shown in Example #1.

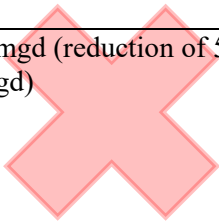
Current Allocation	2025 Demonstrated Demand	New UFA Allocation	New Total Allocation
Total: 20 mgd	Total: 15 mgd	5 mgd (reduction of 5 mgd)	Total: 15 mgd (reduction of 5 mgd)
<ul style="list-style-type: none"> • 10 mgd UFA 			<ul style="list-style-type: none"> • 5 mgd UFA
<ul style="list-style-type: none"> • 10 mgd surface water 			<ul style="list-style-type: none"> • 10 mgd surface water

**DESIGN AID 5:
Guidelines for Preparation of Reuse Feasibility Studies for Consumptive Use
Permit applicants**

https://floridadep.gov/sites/default/files/feasibility_1.pdf

DESIGN AID 6: Calculation of the Maximum Safe Yield of Well for the Prevention of Upconing

This Design Aid 6 is intended solely to provide applicants with useful tools that may assist in presenting reasonable assurance that the withdrawal will not cause harmful upconing during the applicant's preparation of consumptive use permit applications under Chapter 62-41, F.A.C. The equation presented here is from: Schmorak, S. and A. Mercado. 1969. "Upconing of Fresh Water-Sea Water Interface Below Pumping Wells, Field Study." *Water Resources Research*, Vol. 5, No. 6, pp 1290 – 1311, and is based on several assumptions about the aquifer. The absence of applicable conditions may render the equation less relevant to an applicant's well. Therefore, an applicant is cautioned on relying on the equation as the sole basis for demonstrating reasonable assurance that its water withdrawal will not cause harmful saline water intrusion due to upconing, especially in cases where the assumptions do not reflect the conditions at the well site. It is recommended the applicant consult the publication and assumptions to determine its applicability.

When those assumptions have been met, the maximum amount of pumpage from any well may be constrained as follows:

$$Q = \left(\frac{2\pi}{3}\right) (b - l)^2 \left(\frac{\Delta\rho}{\rho}\right) K$$

Where:

- Q is the maximum safe yield of well
- b is the thickness of freshwater
- l is the distance between top of aquifer and well screen
- ρ is the density of freshwater
- $\Delta\rho$ is the change in density of freshwater
- K is the hydraulic conductivity of the aquifer

ERRATA SHEET

NOTE: This errata contains a list of the corrections that have been made since the original publication of the Design Aids for the Central Florida Water Initiative (CFWI) Supplemental Applicant’s Handbook (June 2021).

Page	Correction	Data of Correction
8	TOTAL (Add items 11 and 12)(= line 5 on Part A) changed to TOTAL (Add items 11 and 12)(= line 4 on Part A)	4/4/2024